

K-50L-QG-75

Product Family: K-50

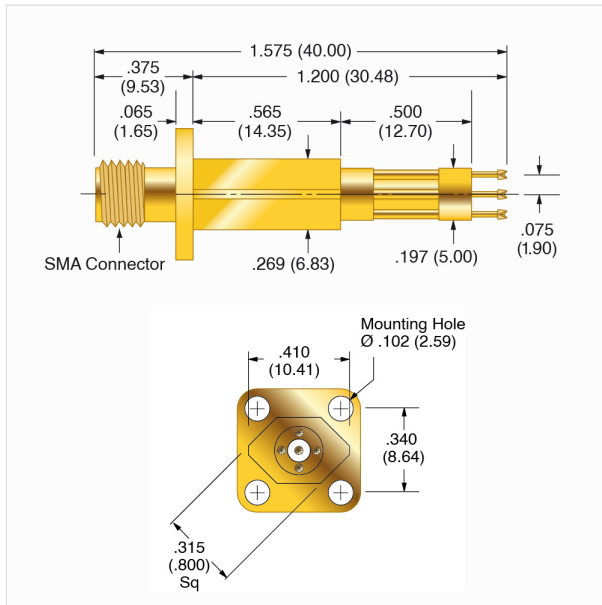

Springs

Force Type - Preload in oz (g) - Rec. Travel in oz (g) -

Spring Material

Standard - 3.74 (106.00) - 14.35 (407.00) -

Additional information:

Mates with standard SMA R. F. connector Replaceable Ground probe: HPA-0L Replaceable Signal probe: SPG-72L-005

Related Products:

HPA-0L

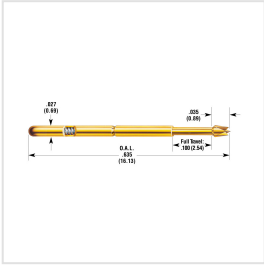

SPG-72L-005

